



## Table of Contents

General information .....	3
Warning and safety .....	3
Warnings .....	3
Cautions .....	3
Notes .....	3
Overview .....	4
General description .....	4
Storage .....	4
Installation .....	4
Operation .....	5
Maintenance .....	5
Disassembly .....	6
Valve assembly .....	7
Spare parts .....	7
Materials and dimensions .....	8-10
Revision history .....	11

# General Information

## Warning and Safety

Dixon Eagle® valves are designed to work safely for their intended use. Failure to know the intended use, or to consider factors such as size, temperature, application, media, pressure, and manufacturers' recommendations when choosing the appropriate valve assembly components can lead to accidents and injuries. Dixon® recommends that all valve assemblies be tested in accordance with ASME and API recommendations and be inspected regularly to ensure that their use remains appropriate and that they are not damaged.

## Warnings

Warnings contain important information related to hazard conditions, procedures, and/or practices that if not followed could result in serious injury or death to personnel or catastrophic damage to equipment or material.



**WARNING:**

A warning will appear with a red triangle below the information the warning pertains to.

## Cautions

Cautions contain important information related to conditions, procedures, and/or practices that if not followed could result in damage to equipment or material.



**CAUTION:**

A caution will appear with a yellow triangle below the information the caution pertains to.

## Notes

Notes contain important information related to conditions, procedures, and/or practices that are intended to provide helpful information, clarification, and/or things to consider.



**NOTE:**

A note will appear with a black triangle below the information the note pertains to.

## Overview

This instruction manual provides information on installation, operation, and maintenance for Eagle J-Series bellows seal globe valves. While flanged ends are shown in the diagrams located in this manual, this document applies to all J-Series bellows seal globe valves 2" and larger with any type of connection, i.e., flanged and butt weld connections.

Pressure and temperature ratings are per ASME B16.34 current revision. Refer to current revision of the standard.

For identification of valve parts please refer pages 8 - 10 – Materials and Dimensions – for reference.

For any questions regarding this manual please contact eaglesales@dixonvalve.com for clarification.

## General Description

The valve is a large cast globe valve with bellows seal.

Primary stem sealing is accomplished by a bellows seal. Backup (secondary) stem sealing is provided by braided graphite packing.

Body/bonnet sealing is accomplished with a spiral wound graphite gasket.

## Storage

To maintain the cleanliness of the valve, do not remove from plastic bag while in storage. Do not remove sealing cap on each end connection until the valve is ready to be installed in the pipeline. The purpose of these sealing caps is to prevent debris from entering the body of the valve.

## Installation

Before installation, inspect welding surfaces of the valve body and piping, flange faces, or threaded surfaces to be certain they are clean and free from any foreign materials.

Disassembling the valve when welding is not recommended. If disassembly is necessary, the components should be marked to maintain the original position.



**WARNING:**

Disassembling the valve will invalidate any factory testing and a proper acceptance test must then be conducted by the user.

When welding, the valve should be fully closed. Heat input should be minimized to prevent seat distortion.

## Operation

Operate the valve by hand; never use a wrench or other tool to turn the handwheel. Over torquing the valve may cause damage. To close the valve, turn the handwheel clockwise. To open the valve, turn the handwheel counterclockwise as shown on the nameplate.

If seat leakage is observed after closing the valve, the valve should be cracked open for a short time to flush any dirt or foreign matter which may have collected on the seat. Close the valve hand tight again and check for leakage.

## Maintenance

Periodic checks with a bubble leak detector fluid at the interface of the body and bonnet, as well as the packing area, is recommended to ensure the integrity of the gaskets and bellows.

Proper lubrication shall be periodically applied to the stem and yoke sleeve threads using the grease fitting. Ensure the lubricant is compatible with the application.

To replace or add packing on-line:

- As a precaution, shut down the line in which the valve is operating.
- Open the valve fully and make sure it is back seated.
- Unfasten the hex bolts retaining the anti-rotation guide plates.
- Remove the guide plates from the stem.
- Loosen and remove the gland bolt hex nuts.
- Push the gland plate and gland bushing up to the yoke sleeve to expose the packing area.
- Add packing or replace packing as needed.
- Reinstall the gland bushing, gland plate, anti-rotation plates, and hex bolts.
- Tighten hex nuts on gland bolts uniformly and evenly, moving from one side to the other.



**CAUTION:**

Do not actuate stem after anti-rotation guide plates have been removed. Doing so will twist the bellows resulting in damage.

## Disassembly



**WARNING:**

Before starting any work on the valve, ensure plant personnel are aware of the work being performed and complete relief of pressure on the line.

Back seat (fully open) the valve. Remove the hex nuts and joint bolts holding the body and bonnet together.

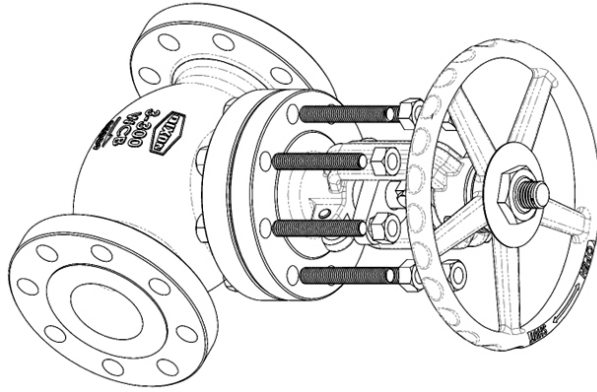

Lift the bonnet and stem assembly out from the body. Remove the gasket.



**CAUTION:**

Ensure the sealing surfaces of the disc do not come in contact with other hard surfaces to prevent scratching.

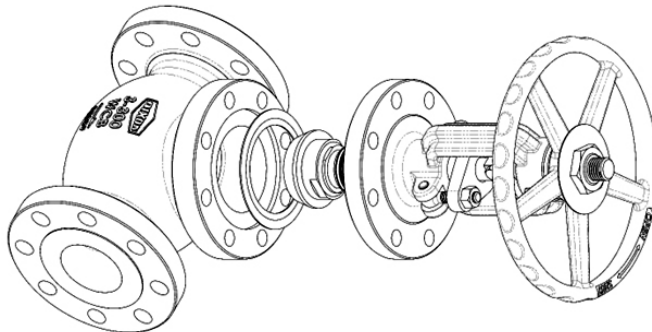

**CAUTION:**

Do not rotate handwheel to extend disc/stem outward from the bonnet. There is no hard stop for the disc after separation from the body to prevent overstretching the bellows and damaging them.

Unfasten the set screw and the handwheel nut. Remove the nameplate and handwheel. If replacing, unfasten the grease fitting and remove.

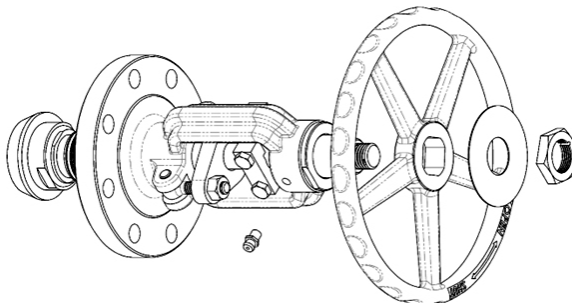

## Valve Assembly

Assemble the valve in the reverse of the disassembly procedure. However, some points listed below are important to follow:

Gasket seating surfaces on the body, bonnet, bellows assembly, and gasket shall be thoroughly cleaned with a cleaning agent such as semiconductor grade acetone before assembling. Threads shall be lubricated. When tightening the joint bolts on the body/bonnet joint, torque the fasteners to the appropriate value from the following table.

Valve Size	Torque (ft - lb) maximum
3"	148
4"	148
6"	263
8"	263



**CAUTION:**

Ensure the bonnet assembly is in the fully open position before installing into the body. Tightening joint bolts against the disc will damage the valve.

Install a new gasket for reassembly. Do not reuse previously installed gaskets.

## Spare Parts

The following parts are recommended to stock as spare parts for normal operation and maintenance.

Description	Material	Required
gasket	graphite/316 stainless steel	1
gland packing	graphite	1 set

Refer to the bill of materials provided on pages 8 and 9 for part numbers.

Bellows are not replaceable in J-Series globe valves, and it is important to consider the cycle life of the bellows for replacement of the valve.

Size	Life Cycle Rating
3"	2,000 cycles
4" and above	1,000 cycles

## Materials and Dimensions

The following drawing and bill of materials contain the materials and dimensions for the J-Series globe valves, 3" to 8".

Refer to Dixon Eagle® valve description key for assembly part numbers.

## Standard Materials for Class 150 Carbon Steel J-Series Globe Valves

### Part Number

Item	Nomenclature	3"	4"	6"	8"	Material	Qty.
1-1	socket weld body	---	---	---	---	ASTM A216 WCB	1
1-2	flanged body	---	---	---	---	ASTM A216 WCB	1
2	seat ring	---	---	---	---	ASTM A105/HF	1
3	bonnet	---	---	---	---	ASTM A216 WCB	1
4	disc	---	---	---	---	ASTM A216 WCB/13CR	1
5	disc nut	---	---	---	---	316L stainless steel	1
6	bellows assembly	---	---	---	---	INC 625/316L stainless steel	1
7	bonnet bushing	---	---	---	---	316L stainless steel	1
8	stem	---	---	---	---	410 stainless steel	1
9	joint bolt	F15013338X93B7, Qty.-8	F16311400X93B7, Qty.-8	F17510525X93B7, Qty.-12	F17510433X93B7, Qty.-16	ASTM A193 B7	varies
10	joint bolt nut	N15013000X942H, Qty.-16	N16311000X942H, Qty.-16	N17510000X942H, Qty.-24	N17510000X942H, Qty.-32	ASTM A194 2H	varies
11	gasket	155033-300	155033-400	155033-600	155033-800	graphite/316 stainless steel	1
12	gland packing	P10002507XBRGR	P18803107XBRGR	P14173106XBRGR	P15753809XBRGR	graphite	1 set
13	packing spacer	---	---	---	---	410 stainless steel	1
14	gland bushing	---	---	---	---	410 stainless steel	1
15	gland plate	---	---	---	---	ASTM A216 WCB	1
16	gland bolt	155115-300	155115-600	155116-600	155115-1000	ASTM A193 B7	2
17	hex nut	N15013000X942H	N16311000X942H	N17510000X942H	N17510000X942H	ASTM A194 2H	2
18	pin	155117-300	155117-600	155014-600	155117-800	1035 carbon steel	2
19	guide plate (A)	155059-300	155059-400	---	---	1035 carbon steel	1
	guide plate	---	---	155043-600	155043-800	1035 carbon steel	1
20	guide plate (B)	155060-300	155060-400	---	---	1035 carbon steel	1
	key	---	---	155055-600	155055-800	1035 carbon steel	1
21	hex bolt	155061-300	155061-400	---	---	ASTM A193 B7	2
	set screw	---	---	155018	155018	carbon steel	1
22	yoke sleeve	155020-300	155046-400	155020-600	155118-1000	ASTM A439 D2	1
23	grease fitting	155045	155045	155045	155125	commercial	1
24-1	thrust collar	155047-300	155047-400	155047-600	155021-800	copper alloy	1
24-2	thrust bearing	---	---	---	---	bearing steel	---
25	yoke cap	155048-300	155048-400	155022-600	155048-800	1045 carbon steel	1
26	handwheel	155120-400	155049-400	155120-800	155120-1000	malleable iron	1
27	handwheel nut	155121-400	155051-600	155121-800	155121-1000	carbon steel	1
28	set screw	155026	155026	155026	155026	carbon steel	1
29	nameplate	---	---	---	---	aluminum	1



## Standard Materials for Class 300 Carbon Steel J-Series Globe Valves

### Part Number

Item	Nomenclature	3"	4"	6"	8"	Material	Qty.
1-1	socket weld body	---	---	---	---	ASTM A216 WCB	1
1-2	flanged body	---	---	---	---	ASTM A216 WCB	1
2	seat ring	---	---	---	---	ASTM A105/HF	1
3	bonnet	---	---	---	---	ASTM A216 WCB	1
4	disc	---	---	---	---	ASTM A216 WCB/13CR	1
5	disc nut	---	---	---	---	316L stainless steel	1
6	bellows assembly	---	---	---	---	INC 625/316L stainless steel	1
7	bonnet bushing	---	---	---	---	316L stainless steel	1
8	stem	---	---	---	---	410 stainless steel	1
9	joint bolt	F16311400X93B7, Qty.-8	F16311400X93B7, Qty.-8	F17510525X93B7, Qty.-12	F17510525X93B7, Qty.-16	ASTM A193 B7	varies
10	joint bolt nut	N16311000X942H, Qty.-16	N16311000X942H, Qty.-16	N17510000X942H, Qty.-24	N17510000X942H, Qty.-32	ASTM A194 2H	varies
11	gasket	155006-300	155006-400	155006-600	155006-800	graphite/316 stainless steel	1
12	gland packing	P1000258XBRGR	P1000258XBRGR	P1400318XBRGR	P1400318XBRGR	graphite	1 set
13	packing spacer	---	---	---	---	410 stainless steel	1
14	gland bushing	---	---	---	---	410 stainless steel	1
15	gland plate	---	---	---	---	ASTM A216 WCB	1
16	gland bolt	155115-300	155115-600	155116-600	155115-1000	ASTM A193 B7	2
17	hex nut	N15013000X942H	N16311000X942H	N17510000X942H	170045	ASTM A194 2H	2
18	pin	155117-300	155117-600	155014-600	155117-1000	1035 carbon steel	2
19	guide plate (A)	155062-300	155062-400	---	---	1035 carbon steel	1
	guide plate	---	---	155017-600	155017-800	1035 carbon steel	1
20	guide plate (B)	155063-300	155063-400	---	---	1035 carbon steel	1
	key	---	---	155056-600	155056-800	1035 carbon steel	1
21	hex bolt	155061-300	155061-400	---	---	ASTM A193 B7	2
	set screw	---	---	155018	155019	carbon steel	1
22	yoke sleeve	155020-300	155020-400	---	---	ASTM A439 D2	1
23	grease fitting	155125	155125	155125	155125	commercial	1
24-1	thrust collar	155123-400	155123-600	155021-600	155021-800	copper alloy	1
24-2	thrust bearing	---	---	---	155065-800	bearing steel	---
25	yoke cap	155119-400	155022-400	---	---	1045 carbon steel	1
26	handwheel	155120-400	155120-600	155120-800	155120-1000	malleable iron	1
27	handwheel nut	155121-400	155121-600	155121-800	155121-1000	carbon steel	1
28	set screw	155026	155026	155026	155026	carbon steel	1
29	nameplate	---	---	---	---	aluminum	1

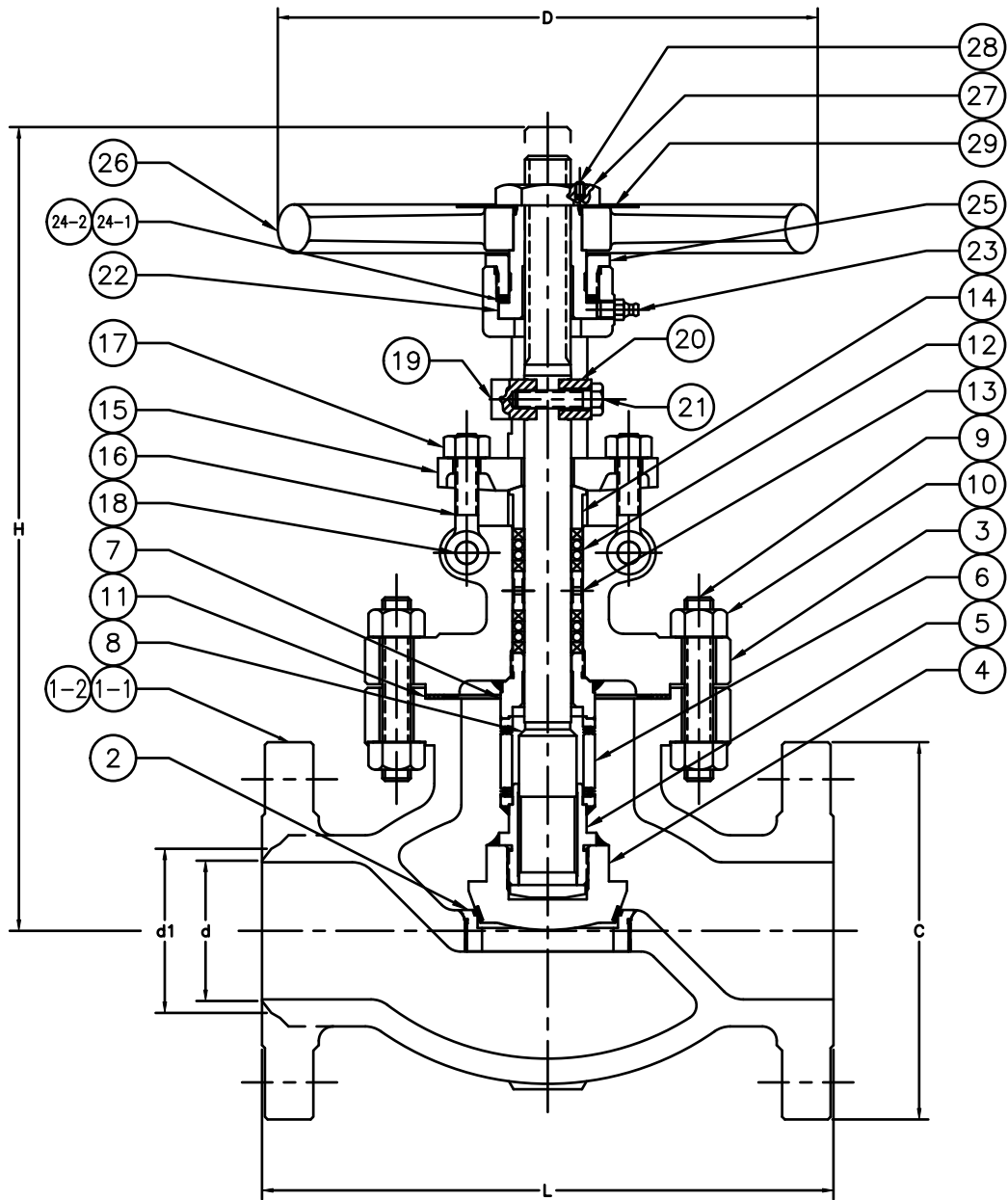

**Flanged and Butt Weld End - ANSI 150**

Size	d	d1	C	L	H	D	LIFT	Cv	Wt (lbs) FL	Wt (lbs) BW
3"	3.068	3.59	7.50	9.50	17	12	0.63	85	90	80
4"	4.026	4.62	9.00	11.50	19	14	0.79	150	150	120
6"	6.065	6.78	11.00	16.00	23	18	1.18	360	260	245
8"	7.981	8.78	13.50	19.50	28	20	1.57	650	430	400

NOTE: Larger sizes and different configurations available, consult eaglesales@dixonvalve.com

**Flanged and Butt Weld End - ANSI 300**

Size	d	d1	C	L	H	D	LIFT	Cv	Wt (lbs) FL	Wt (lbs) BW
3"	3.068	3.59	8.25	12.50	18	12	0.63	85	120	90
4"	4.026	4.62	10.00	14.00	21	16	0.79	150	180	140
6"	6.065	6.78	12.50	17.50	24	18	1.18	360	340	270
8"	7.981	8.78	15.00	22.00	31	20	1.57	650	570	450

NOTE: Larger sizes, different configurations, and class 600 available consult eaglesales@dixonvalve.com

## Revision History

Consult Dixon® for the latest issue of this document.

Revision	ECN Number	Description	Date	Changed By	Approved By
0	---	original issue	06/22/2023	BMS	UCM

